

Nivz Valves & Automation

"Y" TYPE STRAINER

DRG. No.: FYCS31

00

Rev. No.

Pressure Rating : 150 #
 End Connection : Flanged End
 Flange Drilling : As Per ANSI B 16.5, 150#
 Face To Face : ANSI B 16.10, Y Globe Type 150#
 Free Flow Area : 2.5 to 3.0 Times Pipe Flow Area Through Screen

Nomenclature:-

NO.	PART NAME	MATERIAL
1	Body	A 216 GR. WCB/CAST IRON/
2	Cover	ASTM A 351 GR. CF 8/CF8M/CF/3/3M
3	Mesh	S.S. 304/316/304L/316L/BRASS
4	Gasket	CAF/GRAPHITE ASBESTOS/SP. WOUND
5	Bonnet Bolt & Nut	C.S./B7/2H/S.S. 304/316/304L/316L
6	Draining Plug	C.S./S.S. 304/316/304L/316L

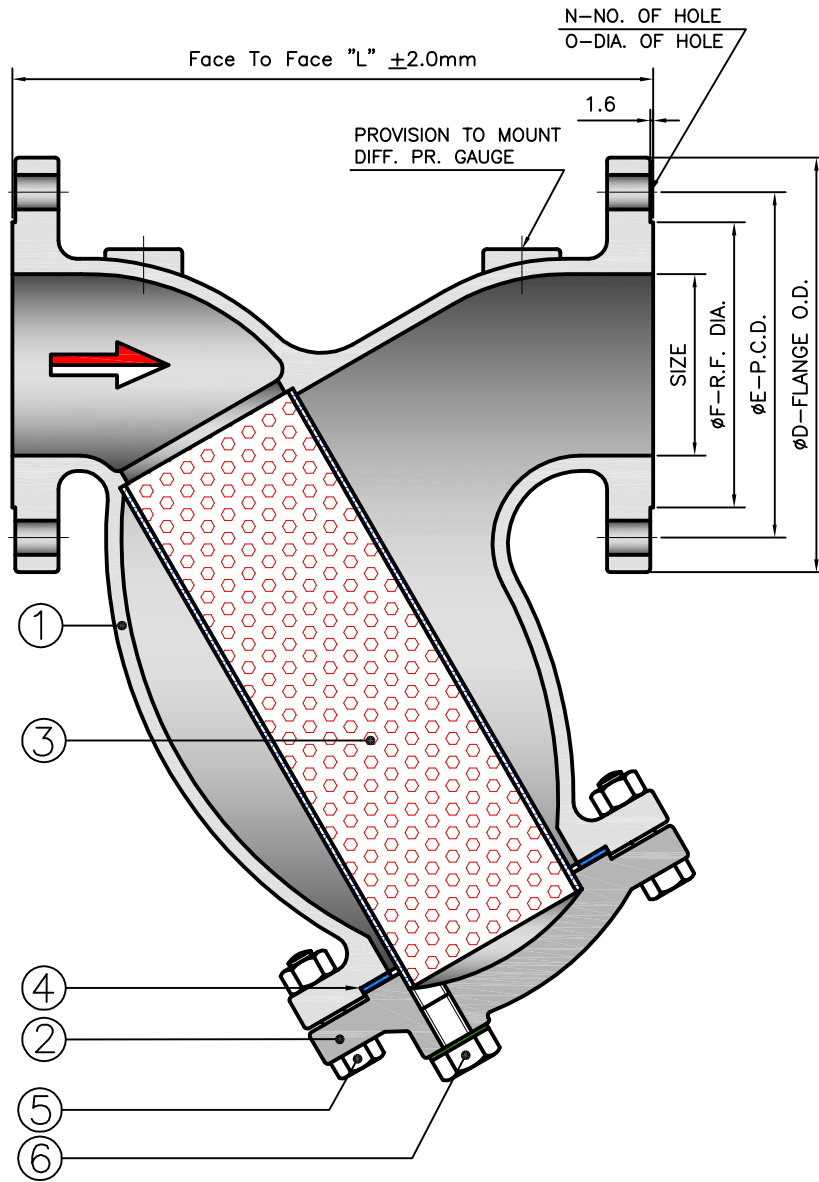

Design Standard : ASME B 16.34

Dimensions [150 Class]

SIZE	25	40	50	65	80	100	150	200	250	300
L	160	200	230	290	310	350	480	600	730	850
ØD	108	127	152.4	177.8	190.5	228.6	279	343	406	483
ØE	79.3	98.4	120.6	139.7	152.4	190.5	241.3	298.4	362.0	431.8
ØF	50.8	73	92.1	104.7	127.0	157.2	215.9	269.9	323.8	381
N	4	4	4	4	4	8	8	8	12	12
ØO	15.8	15.8	19	19	19	19	22.2	22.2	25.4	25.4

All Dimensions Are In mm

Testing Standard : API 598

Test Pressure in PSIG/BAR/KG./CM²

Test	Hydrostatic					
Pr. Rating	150#					
MOC	C.I.			C.S/S.S.		
Body	215	14.7	15	425	29.3	30



VALVES & AUTOMATION

www.nivzvalves.com

Client _____

Order / Enq. No. _____

Job / Project _____

Manufactured By : **Nivz Valves & Automation**, Ahmedabad, Gujarat, INDIA.

Do Not Copy Drawing

©COPYRIGHT

Due to continuous development programme, the design and data given in this leaflet are subject to change without prior notice

Appd. _____

Chkd. _____

Drwn. _____

For Record

For Reference

For Approval