

Nivz Valves & Automation

"Y" TYPE STRAINER, Threaded/Welded End

DRG. No.: **SCYS51**

00
Rev. No.

Pressure Rating : 150 #
 End Connection : Threaded/Socket Weld End
 Socket Weld : As Per ANSI B 16.11
 Screwed End : As Per ASME B 1.20.1
 Face To Face : DIN EN 558-1
 Free Flow Area : 2.5 to 3.0 Times Pipe Flow Area
 Through Screen

Nomenclature:-

NO.	PART NAME	MATERIAL
1	Body	A 216 GR. WCB/CAST IRON/
2	Cover	ASTM A 351 GR. CF 8/CF8M/CF/3/3M
3	Mesh	S.S. 304/316/304L/316L/BRASS
4	Gasket	CAF/GRAPHITE ASBESTOS/SP. WOUND
5	Cover Bolt & Nut	C.S./B7/2H/S.S. 304/316/304L/316L
6	Draining Plug	C.S./S.S. 304/316/304L/316L

Bolted Cover, Y Type Strainer

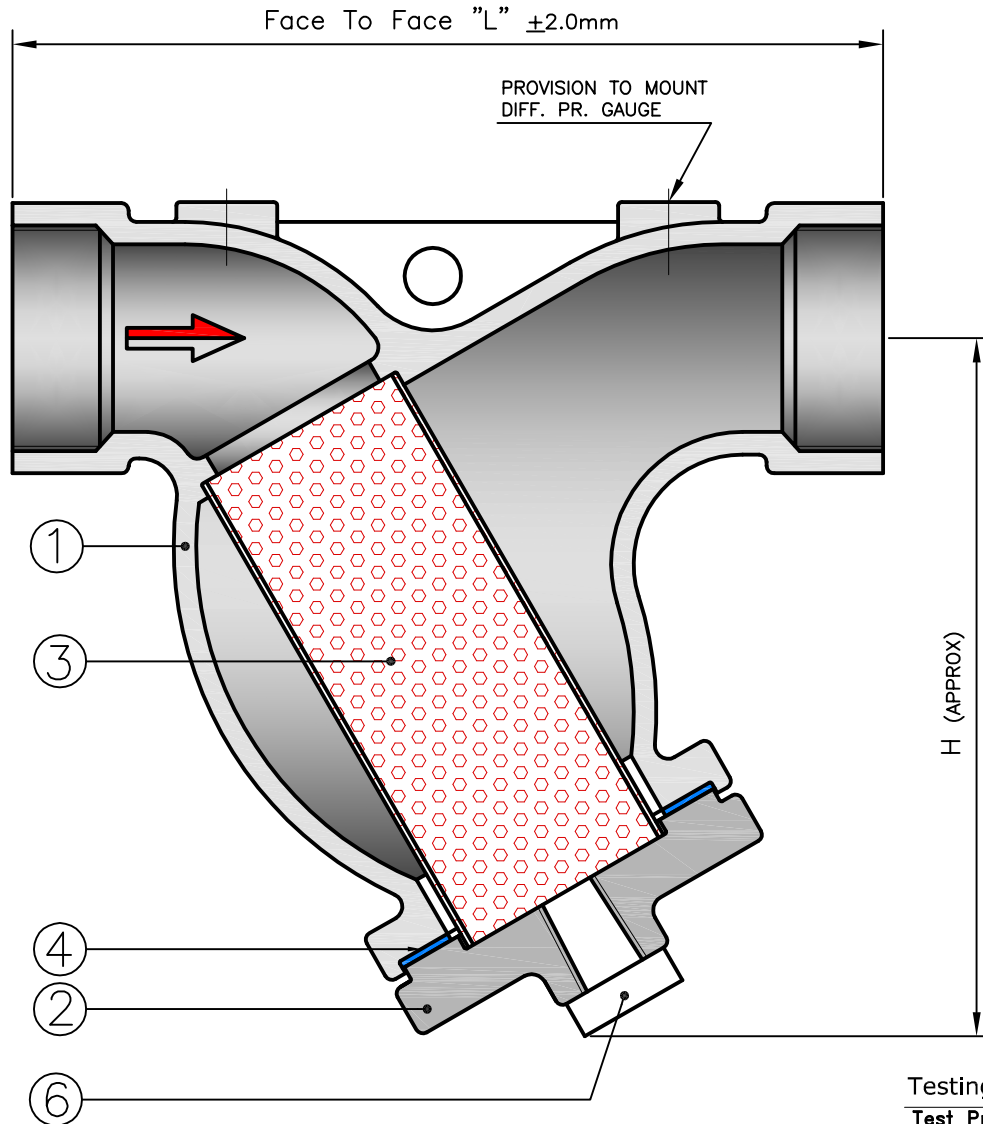

Testing Standard : API 598

Test Pressure in PSIG/BAR/KG./CM ²						
Test	Hydrostatic					
Pr. Rating	150#					
MOC	C.I.		C.S./S.S.			
Body	215	14.7	15	425	29.3	30

Design Standard : ASME B 16.34

Dimensions [150 Class]

SIZE	15	20	25	40	50	65	80
L	160	160	160	200	230	290	310
H	130	130	130	190	205	275	300

All Dimensions Are In mm



VALVES & AUTOMATION
www.nivzvalves.com

Client _____

Order / Enq. No. _____

Job / Project _____

Manufactured By : **Nivz Valves & Automation**, Ahmedabad, Gujarat, INDIA.

Do Not Copy Drawing

©COPYRIGHT

Due to continuous development programme, the design and data given in this leaflet are subject to change without prior notice

Appd. _____

Chkd. _____

Drwn. _____

For Record

For Reference

For Approval